



# TH220B

## Telehandler



## SPECIFICATIONS

### Engine

Engine Model	Cat® 3054E
Gross Power	
Standard	74.5 kW/101.3 hp
Optional	92 kW/125 hp
Net Power	
Standard	71.8 kW/97.6 hp
Optional, Standard fan	89.2 kW/121.3 hp
Optional, Reversible fan	87 kW/118.3 hp
Maximum Torque	
Standard	410 Nm
Optional	450 Nm
Bore	105 mm
Stroke	127 mm
Displacement	4.4 liter

- All engine horsepower (hp) are metric.
- Engine meets EU directive 97/68/EC Stage II emission requirements.
- Maximum net power shown is the power available at the flywheel when the engine is equipped with fan, aircleaner, muffler and alternator.
- Maximum torque shown is at 1400 rpm.

### Weights

Operating Weight	6700 kg
------------------	---------

### Operating Specifications

Rated Load Capacity	3500 kg
Maximum Lift Height	6100 mm
Load at Max Height	2500 kg
Maximum Forward Reach	3290 mm
Load at Max Reach	1500 kg
Top Travel Speed	40 km/h

### Hydraulic System

Maximum System Pressure	250 bar
Maximum Pump Flow	113 liter/min
Pump Type	Variable Displacement Load Sensing Axial Piston Pump
Auxiliary hydraulic supply	
Intermittent	90 liter/min
Continuous	60 liter/min

### Service Refill Capacities

	liter
Fuel Tank	115
Hydraulic Tank	60

### Transmission Speeds

Forward	km/h
1	7
2	13
3	22
4	34
5	40
Reverse	
1	7
2	13
3	22

### Boom Performance

	seconds
Boom Up	5
Boom Down	4
Tele In	5
Tele Out	6
Crowd Forward (dump)	3
Crowd Backward	3
Combined	
Up and Out	10
Down and In	5

Dimensions

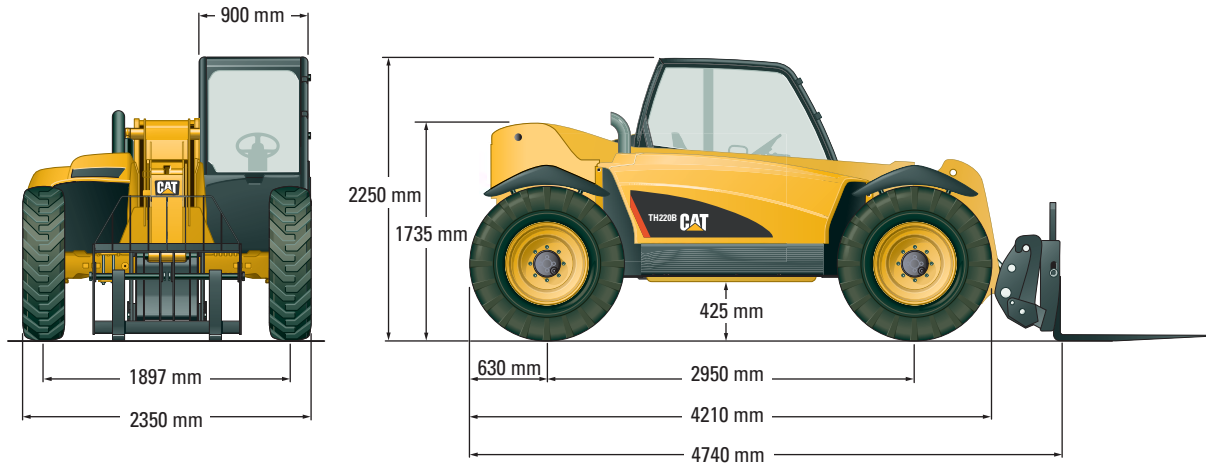

Load Chart

